

## PATENT SPECIFICATION

537,851



Application Date: April 17, 1940.

No. 6957/40.

Complete Specification Accepted: July 9, 1941.

## COMPLETE SPECIFICATION

## Improvements in or relating to Pyrophoric Lighters

We, BARNETT PEARLMAN, of 28, St. Stephens Close, Avenue Road, London, N.W.8, and JOHN HENRY COLLINS, of 20 The Ridgeway, Golders Green, N.W.11, both British subjects, do hereby declare the nature of this invention and in what manner the same is to be performed, to be particularly described and ascertained in and by the following statement:—

This invention relates to pyrophoric lighters for cigarettes, cigars and the like, of the kind in which a wick snuffer and a cap, adapted to cover both the wick snuffer and the flint wheel, are carried by an arm pivotally mounted on the lighter casing.

In previous known constructions of such pyrophoric lighters, the wick snuffer, cap and arm have been secured together by soldering, with the attendant disadvantage of a relatively weak joint between the three parts, and the further factor that in manufacturing the operation of soldering is relatively costly.

By means of the present invention, the use of a soldering operation is dispensed with, and a positive and relatively strong and reliable joint between the snuffer, cap and arm is obtained.

According to the invention, the snuffer, the cap and the arm are firmly secured together to form an integral whole by means of a single rivet, which is preferably formed integrally with and as an extension of one of the three members in question. Thus, the rivet may be formed as an upward extension of the snuffer, as a downward extension of the cap, or as coaxial upward and downward extensions of the arm.

The invention will now be described with reference to the accompanying drawings, in which

Figure 1 is a perspective view, showing the three parts prior to assembly, in this case the rivet being formed as an upward extension of the wick snuffer, and

Figure 2 is a central sectional view of the parts shown in Figure 1, after assembly thereof upon a lighter casing.

As shown in the drawing, an arm 1, adapted to be pivotally mounted on the lighter casing as indicated at 2 in Figure 2, has associated therewith a cap 3 and a wick snuffing member 4.

The arm 1 has an extension 10 formed at the end thereof intended to carry the wick snuffer and cover cap, a hole 5 being provided in such extension. The said extension is adapted to be passed through an aperture 7 in a side wall of the cap 3, the shape of such aperture and the cross-sectional shape of the extension 10 corresponding one to the other and being such that relative movement of the extension in the aperture is prevented.

A wick snuffer 4 of the known kind is formed with a pin or rivet 8 extending upwardly therefrom, as shown in the drawing, such pin 8 being adapted to pass through the hole 5 in the extension 10 of the arm 1 and through a hole 6 provided in the upper wall of the cap 3.

Thus, to assemble the three parts and secure them positively together into an integral whole, the extension 10 is passed through the aperture 7, the pin 8 on the snuffer 4 is passed through the hole 5 in the extension 10 and through the hole 6 in the cap 3, and extends upwardly from such cap to a sufficient extent to permit of its end being expanded or riveted in the known manner to hold the three parts securely and positively together, as shown in Figure 2.

It will readily be appreciated that the joint between the three members in accordance with the invention has the advantages over the prior constructions in which soldering was employed that a rigid and relatively strong joint is obtained, such that the parts form substantially one integral whole, and that such joint is very simply and economically formed, the soldering operation being dispensed with.

Having now particularly described and ascertained the nature of our said invention and in what manner the same is to be performed, we declare that what we claim is:—

1. A pyrophoric lighter of the kind in which a wick snuffer, and a cap adapted to cover the flint wheel and the snuffer, are carried by an arm pivoted to the lighter casing, characterised in that the snuffer, the cap and the arm are positively secured together to form an integral whole by means of a single rivet.

2. A pyrophoric lighter as claimed in Claim 1, wherein the rivet is formed as an

[Price 1/-]

upward extension of the wick snuffer.

3. A pyrophoric lighter as claimed in Claims 1 or 2, wherein the arm has an extension formed thereon to extend inwardly through an aperture provided therefor in a side wall of the cap, and a pin projecting upwardly from the snuffer passes through holes provided in such extension of the arm and in the upper wall of the cap, the upper end of the pin being expanded in a known manner to hold the

cap, the snuffer and the arm together as an integral whole.

4. A pyrophoric lighter substantially as hereinabove described with reference to the accompanying drawing. 15

Dated this 17th day of April, 1940.

D. YOUNG & CO.,

11 & 12, Southampton Buildings,  
London, W.C.2,

Agents for the Applicants.

*Fig. 1.*

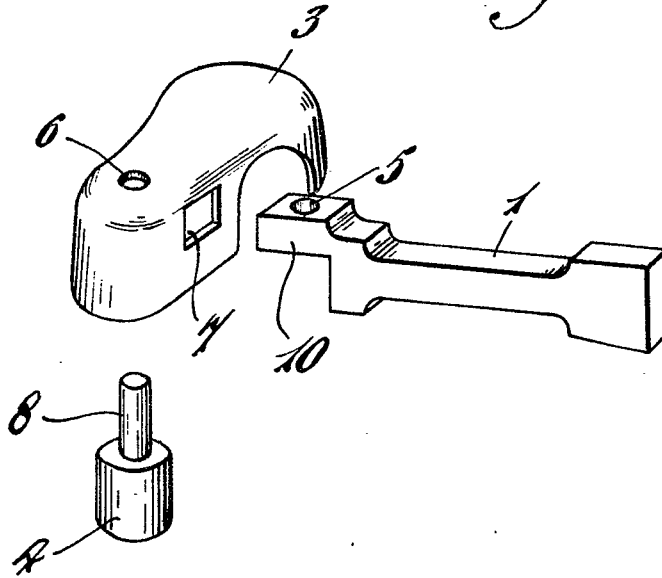

*Fig. 2.*

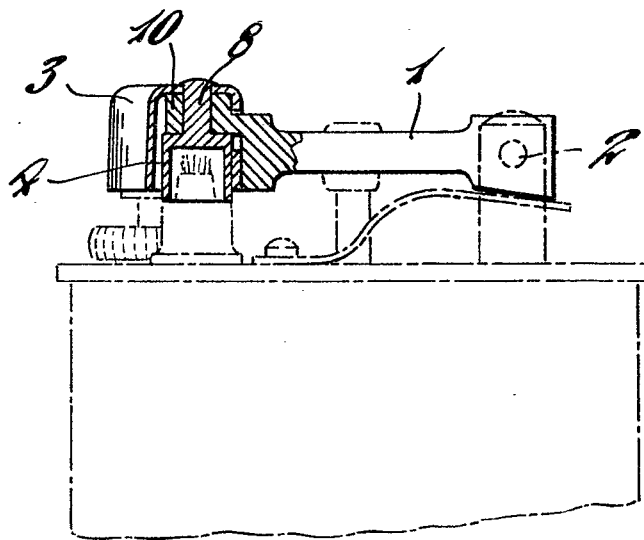

*[This Drawing is a full-size reproduction of the Original.]*