

PATENT SPECIFICATION



Application Date: May 14, 1934. No. 14498/34.

438,367

Complete Specification Left: May 13, 1935.

Complete Specification Accepted: Nov. 14, 1935.

PROVISIONAL SPECIFICATION

Improvements in Flint Lighters for Pipes, Cigarettes and the like

We, KARL WIEDEN, G.M.B.H., a German Company, of Scheffelstrasse 26, Postfach 80, Solingen-Ohligs, Germany, and ERICH WIEDEN, a German citizen, of the same address, do hereby declare the nature of this invention to be as follows:—

This invention relates to flint lighters for pipes, cigarettes and the like and concerns lighters of the kind wherein a cover which normally lies over a flame-emission aperture, is lifted by exerting hand pressure on another part of the lighter, so as to expose the flame and subsequently closes again when the pressure is released. The invention provides an improved and simply constructed lighter of this form.

According to this invention there is provided a lighter comprising a casing having a flame-emission opening in its upper part, a pivoted cover for said opening, the pivot being positioned adjacent one end of the opening and a movable end portion to said casing, said end portion being pivotally attached to the main body of the casing adjacent the bottom thereof and normally projecting from said main body. The said movable end portion is operatively coupled to the pivoted cover aforesaid so that by the operation of pressing on said end portion when the lighter is grasped in the hand the pivoted cover will be opened. The friction wheel which bears on the flint also is operatively coupled to the movable end portion of the casing in order to effect ignition by the aforesaid operation of pressing in said end portion.

In a preferred embodiment of the invention there is detachably fitted in the end of the casing remote from that end having the movable end portion, a tank adapted to contain liquid fuel, the feeding opening of which is closed by means of a porous body such as a felt washer fitted on a closure plug. A partition provided within the casing forms a compartment adjacent the tank for wadding which will become moistened to feed the wick. The wick passes through a nozzle fitted into an inclined upper part of the partition, and the exposed end thereof is

[Price 1/-]

covered when the lighter is not in use by a wick cap having an inclined outer face to seat flat on the nozzle.

The wick cap is affixed to a cover in the form of a flap pivoted on an axle on which is mounted also a friction wheel against which bears a flint pressed upon by a spring, said flint and spring being accommodated in a tube which passes through the partition aforesaid.

The pivoted end member aforesaid preferably is hollow and is adapted to pass into the main casing, the latter being shaped with an oblique end to permit movement of said end member. The latter is furnished at its free upper part with parallel spaced-apart arms which pass over the sides of the cover flap, and each of said arms is formed with a vertical slot which engages on a pin provided on said cover flap at a position below and to the near side of the axle aforesaid, this constituting the means for lifting the cover flap by pressing on the end member. A spring situated within the end member exerts effort to force out said member and thereby close the cover flap.

Preferably the casing is made narrow in width, the opening which is provided for the cover-flap being centrally disposed in the narrow top thereof. The sides of the casing are cut-away in V-fashion in the locality of the opening to admit air for combustion, the cover flap when closed lying flush with the top of the casing.

The cover flap is provided with suitable spring means adapted to function as a pawl in engaging ratchet teeth formed on one side of the friction wheel, so that said wheel will be operated and the wick ignited simultaneously with the lifting of the cover flap.

Dated this 14th day of May, 1934.
KINGS PATENT AGENCY LIMITED,
By BENJ. T. KING, C.I.Mech.E.,

Director,
Registered Patent Agent,
146a, Queen Victoria Street, London,
E.C.4,
Agents for the Applicant.

Price 4s 6d

COMPLETE SPECIFICATION

Improvements in Flint Lighters for Pipes, Cigarettes and the like

- We, KARL WIEDEN, G.M.B.H., a German Company, of Scheffelstrasse 26, Postfach 80, Solingen-Ohligs, Germany, and ERICH WIEDEN, a German citizen, of the same address, do hereby declare the nature of this invention and in what manner the same is to be performed, to be particularly described and ascertained in and by the following statement:—
- 10 This invention relates to friction lighters for pipes, cigarettes and the like and concerns lighters of the kind wherein a cover which normally closes a flame-emission aperture in the lighter body, is displaced therefrom by exerting hand pressure on a pivoted part of the lighter, so as to expose the flame and subsequently closes again when the pressure is released, the said manipulation also actuating a friction wheel to ignite the wick.
- 15 It has already been proposed in a lighter of the foregoing kind to form a flame-emission opening approximately in the centre of the length of a narrow wall of the body and to cut away the adjacent side walls of the body in the locality of the opening and to provide for said opening a cover which is adapted to swivel into the body and which when it returns to closed position forms a substantially flush continuation of the wall having the opening. In such prior proposal a spring-pressed pivoted end to said body had its pivot situated adjacent the wall having the opening, and the remote free portion of said pivoted end was indirectly coupled to the friction wheel and pivoted cover aforesaid. The wick tube and flint-holding tube passed through a partition set at right angles to the body wall.
- 20 It has also been proposed in a lighter in which the friction wheel is actuated by a pivoted cap, to actuate the cap by means of a spring-loaded rocking lever which forms a side wall of the lighter and is connected with the cap by means of a pin disposed eccentrically to the axis of rotation of the cap, and connected with the fuel container by means of a pin or the like arranged to slide in an inclined slot in the container, the wick and flint tubes being inclined towards the friction wheel, whilst in the specification of Patent No. 424,613 (applied for but not published at the date hereof) the invention claimed is the direct engagement, by pins and teeth of an operable lever (forming part of the body) with a pivotally mounted closing cap coupled with the spark-producing means so that the cap is opened and the spark producing means actuated by exerting pressure on the lever.
- 25 The present invention provides an improved lighter comprising the following features, essentially in combination, namely a body formed with a flame-emission opening approximately centrally disposed in a narrow top wall of said body, cut away portions in the side walls of the body in the locality of the opening, a pivoted cover for said opening adapted to open externally and when closed to form a flush continuation of the body top having the opening, a spring-pressed pivoted end to said body having its pivot situated near the bottom of the body and being operatively engaged directly at its upper part with the pivoted cover and adapted to actuate also a friction wheel through such engagement, a partition within the body forming a wall of a fuel container, and a wick tube and a flint-holding tube passing through said partition and inclined towards the friction wheel.
- 30 In the accompanying drawings, which illustrate a lighter constructed according to the invention, Figure 1 is a plan view of said lighter. Figure 2 is a side view thereof. Figure 3 is a longitudinal section drawn to a larger scale showing the parts in normal position, and Figure 4 is a view similar to Figure 3 showing the parts in the position they assume when the lighter is operated.
- 35 Referring to the drawings the lighter comprises a hollow body or casing 5, into one end of which is detachably fitted a tank 6 adapted to contain liquid fuel, the feeding opening of which is closed by means of a porous body such as a felt washer 8 fitted on a closure plug 9. A partition 10 provided within the casing forms a compartment 11 adjacent the tank for wadding which will become moistened to feed the wick, 12. The wick 12 passes through a nozzle 13 fitted into an inclined upper part of the partition 10, and the exposed end thereof is covered when the lighter is not in use by a wick cap 14 having an inclined outer face to seat flat on the nozzle.
- 40 The wick cap 14 forms part of a cover in the form of a flap 15 pivoted on an axle 16 on which is mounted also a friction wheel 17 against which bears a flint 18 pressed upon by a spring 19, said flint and spring being accommodated in a

tube 20 which passes through the partition 10. The axle 16 is mounted in a forked extension of the said tube 20.

The body is provided with an end member 21 (preferably hollow) which is pivoted at 22 and adapted to pass into the body, the latter being shaped with an oblique end 23 to permit movement of said end member. The latter is furnished at its free upper part with parallel spaced-apart arms 24 which pass over the sides of the cover flap 15, and each of said arms is formed with a vertical slot 26 which engages on a pin 27 provided on said cover flap at a position below and to the near side of the axle 16 aforesaid, this constituting the means for lifting the cover flap by pressing on the end member 21. A spring 28 situated within the end member exerts effort to force out said member and thereby close the cover flap.

The body is made narrow in width, the opening which is provided for the cover flap being centrally disposed in the narrow top thereof. The sides of the body are cut-away in V-fashion in the locality of the opening as shown at 29 to admit air for combustion, the cover flap when closed lying flush with the top of the casing.

The cover flap is provided with suitable spring means (not shown), adapted to function as a pawl in engaging ratchet teeth formed on one side of the friction wheel, so that said wheel will be operated and the wick ignited simultaneously with the lifting of the cover flap.

Having now particularly described and ascertained the nature of our said invention and in what manner the same is to

be performed, we declare that what we claim is:—

1. A friction lighter comprising in combination a body formed with a flame-emission opening approximately centrally disposed in a narrow top wall of said body, cut away portions in the side walls of the body in the locality of the opening, a pivoted cover for said opening adapted to open externally and when closed to form a flush continuation of the body top having the opening a spring-pressed pivoted end to said body, having its pivot situated near the bottom of the body and being operatively engaged directly at its upper part with the pivoted cover and adapted to actuate also a friction wheel through such engagement, a partition within the body, forming a wall of a fuel container and a wick tube and a flint-holding tube passing through said partition and inclined towards the friction wheel.

2. A friction lighter as claimed in claim 1 wherein a common pivot axle for the pivoted cover and friction wheel is fitted in a forked extension of the flint-holding tube.

3. A friction lighter constructed and operating substantially as herein described with reference to the accompanying drawings.

Dated this 1st day of May, 1935.
KINGS PATENT AGENCY LIMITED,
By BENJ. T. KING, C.I.Mech.E.,

Director,
Registered Patent Agent,
146a, Queen Victoria Street, London,
E.C.4,
Agents for the Applicants.

FIG. 1.



FIG. 2.

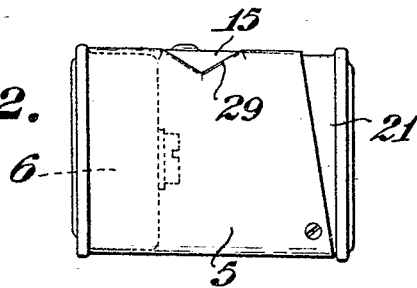

FIG. 3.

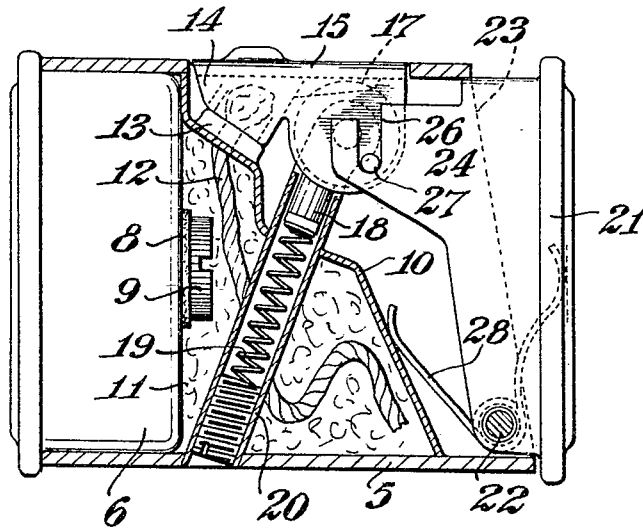
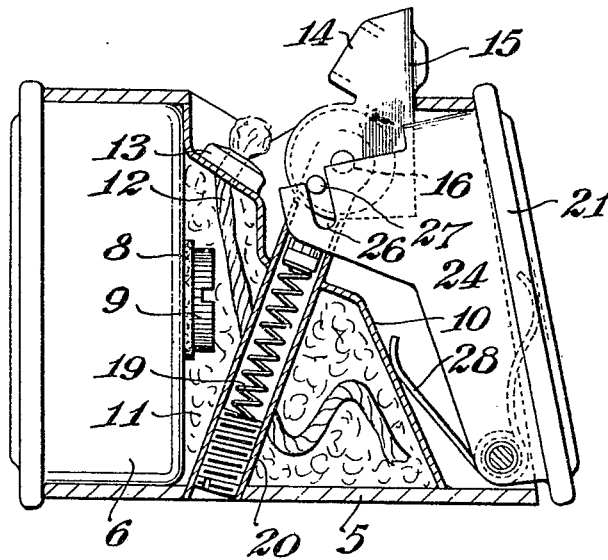

FIG. 4.



[This Drawing is a reproduction of the Original on a reduced scale.]